

PR051 TWO WAYS REFLEX STAGE MONITOR

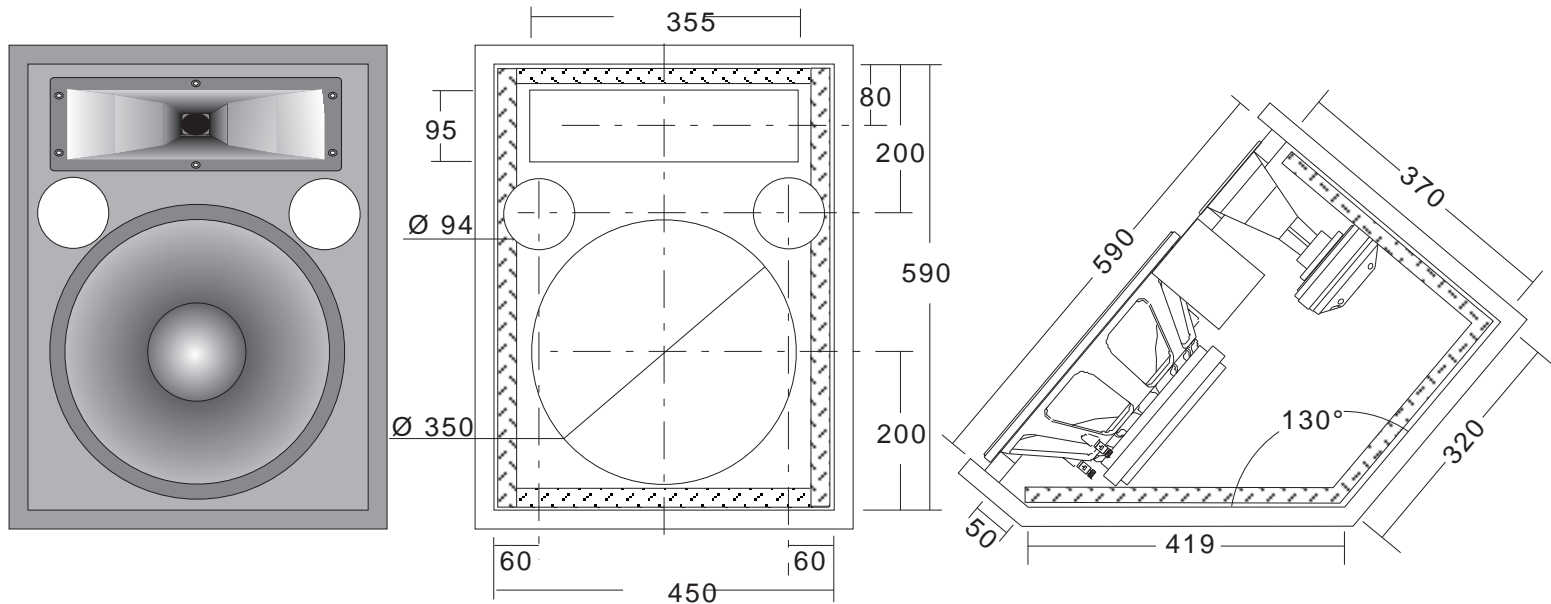

COMPONENTS	
L F	15.00 W2
H F	1.44 CD 2
Horn	PR 380
Crossover	PF203
Max Power	500 W
Nominal Power	250 W
Impedance	8 Ω

SPECIFICATIONS

Sensitivity 1W/1m	:	100	dB
Net volume Vb	:	70	dmc
Tuning Frequency Fb	:	50	Hz
Frequency range	:	20 ÷ 20000	Hz
Crossover Frequency	:	2000	Hz

